



warranted for 350lbs use...



A DIVISION OF *Leggett & Platt* CANADA CO.



## T4002 PLUS+

The T4002-Plus+ Knee-Tilt mechanism is rated and warranted for 350lb use. Providing more spring power than ever before, this mechanism has been re-engineered in order to accommodate larger seating requirements for executive chairs.

This knee tilt promotes keeping your feet on the ground and your thighs parallel to the floor when you recline, thus reducing the pressure on your thighs.

The T4002-Plus+ mechanism has height adjustment (TA), tilt tension (TL), and infinite lock on the several available separate back adjust options.

Complementing the package mechanism package includes options such as Integrated Seat Slider providing 2.5" of travel and Rotary Side Tension.

# EXTRAS & OPTIONS

## SEPARATE BACK OPTIONS



## SIDE TENSION OPTIONS



## CAM ACTIVATED SEAT SLIDER & 3PC LEVER OPTIONS



## HANDWHEEL OPTIONS



## ARM BRACKET OPTIONS



## SPECIFICATIONS

### MECHANISM FEATURES

- TA Top Activation
- TL Infinite Tilt Lock
- HD Heavy Duty Spring
- Auto Seat Slider
  - Integrated Automotive Style and Cam Activated Seat Sliders (2.50" of travel seat slider factory installed)

### FORWARD TILT OPTIONS

- FT Front Tilt Bumper 6° forward

### ARM BRACKETS

- ADJ2 Adjustable Arm Brackets
- AT2 Fixed Arm Brackets

### GAS CYLINDER TAPERS

- 17-4E Extruded 17-4 Taper

### MECHANISM ANGLES

- Seat
  - Forward Tilt 3.5° rearward
  - Rearward Tilt 15°
- Back
  - 16° Travel on Euro back

\* 3pc lever paddle options

\* Variable locations available by welding in different locations on the seat plate or integrated seat slider  
Customer is to specify arm bracket Length and Location for the ADJ2 Welded Arm Bracket.

# NORTHFIELD T4002 PLUS+

CAD

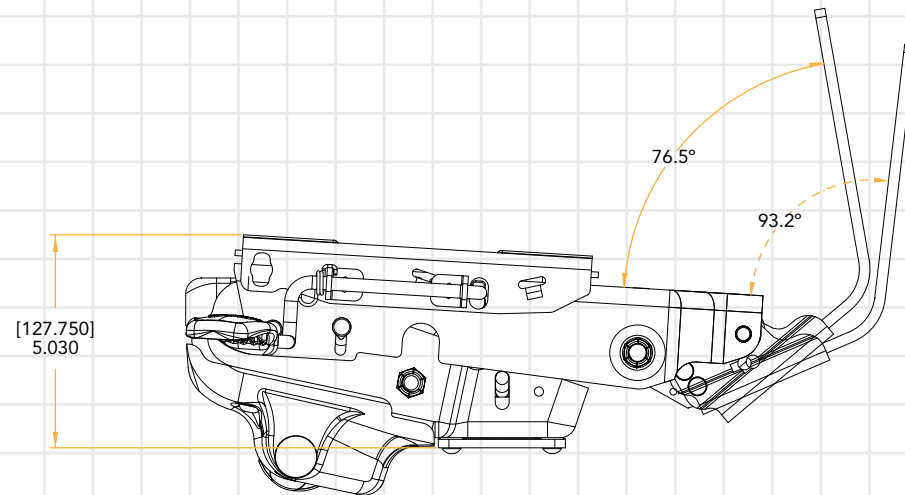
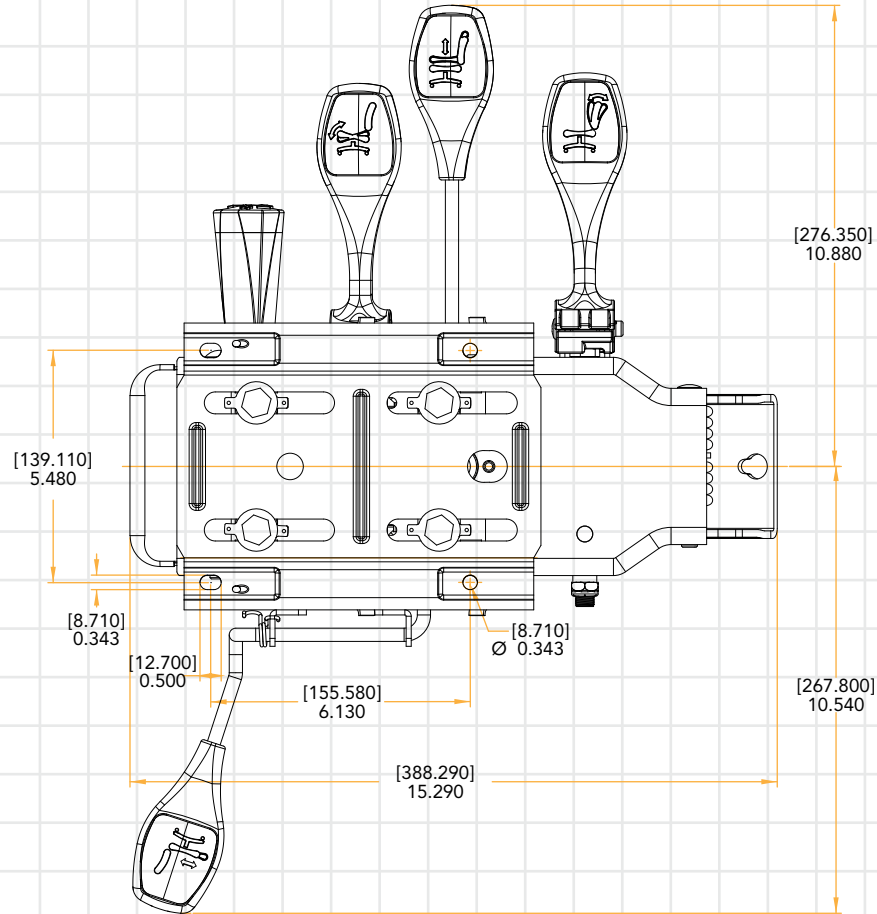

[MILLIMETRES]  
INCHES

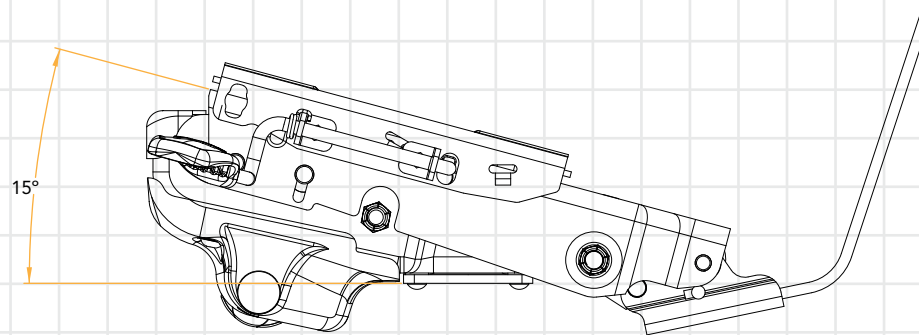
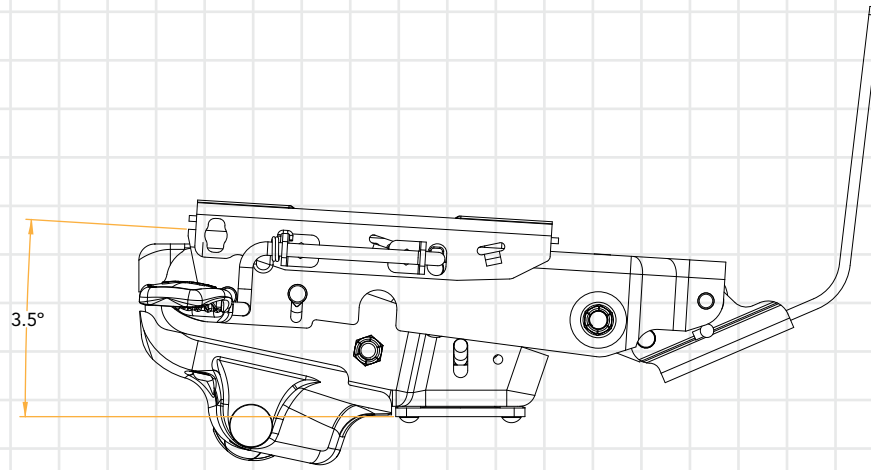

[MILLIMETRES]  
INCHES

NORTHFIELD  
**T4002 PLUS+**

CAD

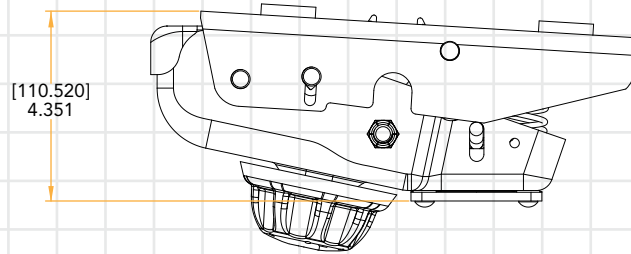
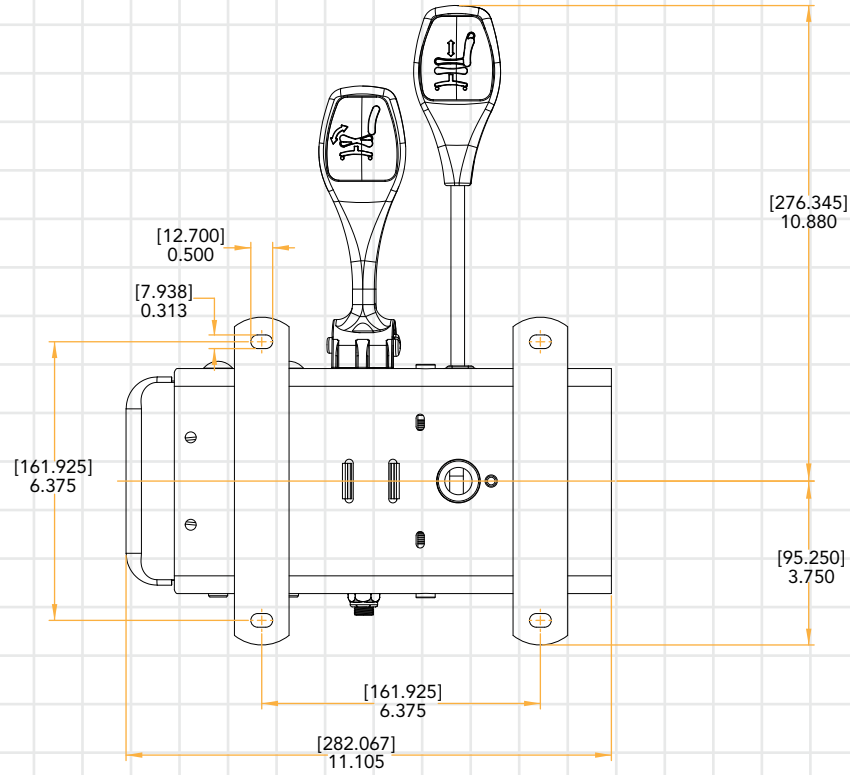

[MILLIMETRES]  
INCHES

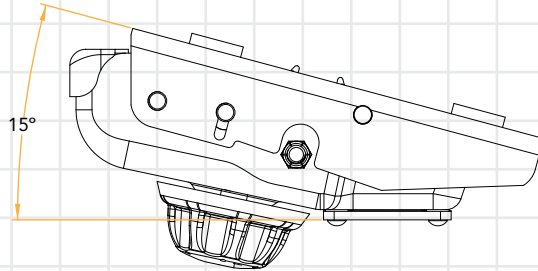
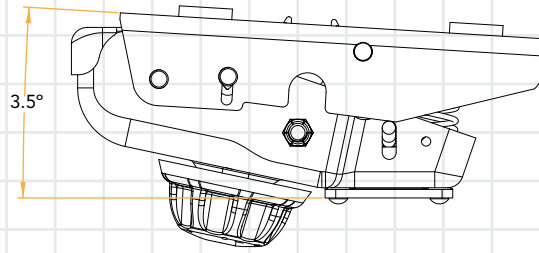

[MILLIMETRES]  
INCHES

**Northfield Metal Products Ltd.**  
*a division of Leggett & Platt Canada Co.*  
195 Bathurst Drive  
Waterloo, ON N2J 3Z9 CANADA

**phone:** (519) 884-1860  
**toll-free:** 1 (866) 362-9301 (Canada/USA)  
**toll-free:** 1 (800) 362-9301 (International)  
**fax:** (519) 884-5476  
**email:** sales@northfieldmetal.on.ca

**BIFMA**  
INTERNATIONAL

Manufacturer certifies  
that this product meets  
or exceeds applicable  
ANSI/BIFMA standards.



© 2011 Northfield Metal Products Ltd. The shape of a Northfield Chair Control is a TRADE-MARK of Northfield Metal Products. The shape is your guarantee that you have purchased a genuine, high quality product made by Northfield. Northfield Metal Products Ltd. is a division of Leggett & Platt Canada Co. Printed in Canada.