

## Synchronized Tilt Mechanism

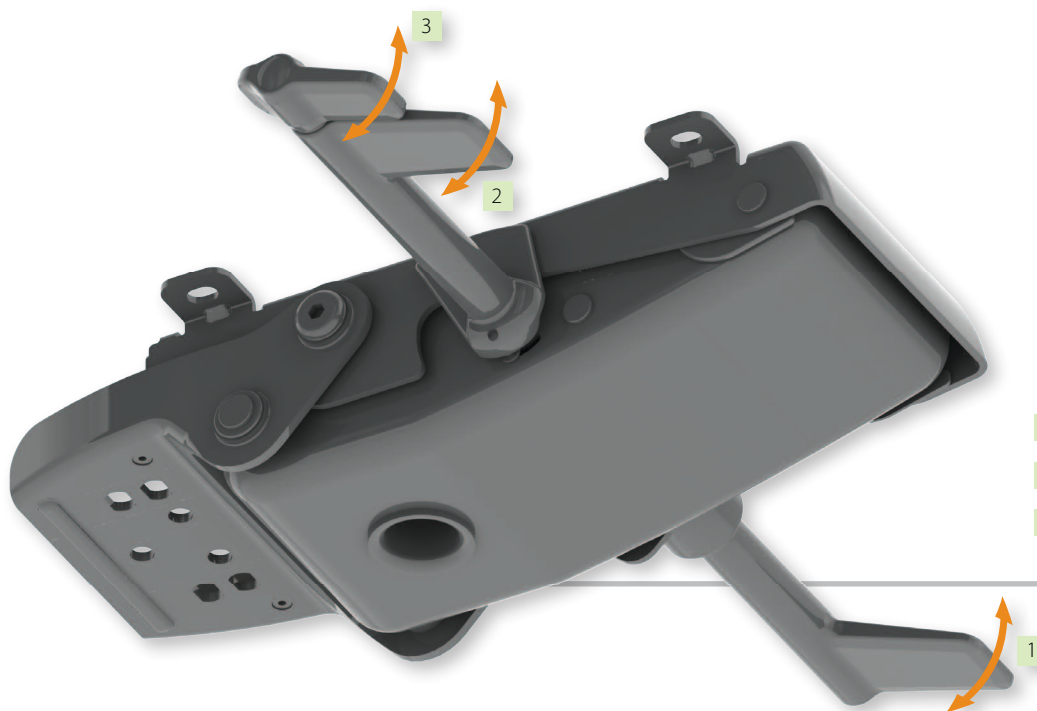

- 1 Travel Restrictor
- 2 Seat Height Adjustment
- 3 Tension Adjustment

LP02 is a synchro mechanism which integrates a unique self-weighting system capable of automatically responding to the torque requirements of different users. The easily accessed side tension handle allows users to adjust personal preferences for torque/resistance, based on body size and task requirements.

The mechanism also features a side activated three position travel limiter. With the mechanism's low profile configuration and external back support member, visual boundaries for design are minimized, thus enabling a new look and freedom in chair styling and performance.

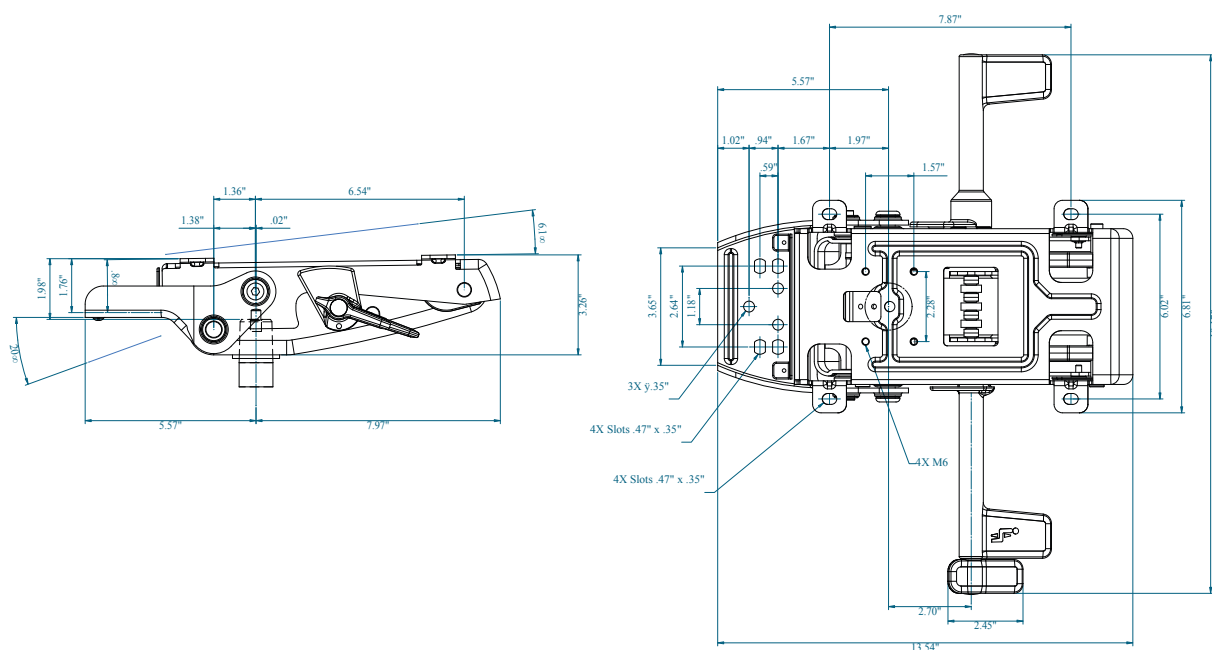

10521\_LP\_6/11 © 2011 Leggett & Platt, Incorporated

Pivot	Back Travel	Seat Travel	Seat/Back Recline Ratio
Synchro	20°	6.1°	3.3 to 1